

1961

Corvair 95

AND

Greenbrier

SPORTSWAGON

OWNERS GUIDE



RAMPSIDE



GREENBRIER SPORTSWAGON



CORVAN

Whether you have one of the three sturdy delivery type Corvair 95 vehicles or the equally sturdy "family size" Greenbrier Sportswagon, you are assured of the usual high degree of Chevrolet excellence in design and manufacture. This booklet contains information and suggestions designed to allow you to more quickly and more fully enjoy the advantages and features built into your Corvair.

Your Chevrolet Dealer is well trained and equipped to inspect and service your Corvair 95 and keep it ready to provide new car service and performance. Have him inspect and service your car at regular intervals.

We would like to take this opportunity to thank you for choosing Chevrolet—and to assure you of our continuing interest in your motoring pleasure and convenience.

CHEVROLET MOTOR DIVISION

• GENERAL MOTORS CORPORATION
DETROIT 2, MICHIGAN

**TABLE
OF
CONTENTS**

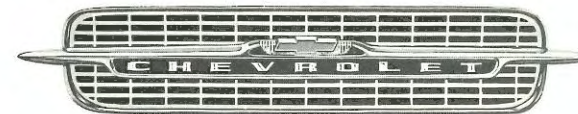

	<i>Page</i>
Operating Instructions	2
Instruments	8
Controls	10
Cleaning Hints	22
Maintenance and Lubrication	24
Specifications	38
Service Accessories	40
Minor Trouble Shooting Guide	41
Trouble Shooting Procedures	42
Index	45
Owner Protection Policy	Inside Back Cover

All information contained in this booklet is based on the latest product information available at the time of printing. The right is reserved to make changes at any time without notice.

BREAKING-IN PERIOD

Sound design and precision manufacturing methods will permit you to operate your new Corvair in a normal manner from its very first mile without adhering to a formal "break-in" schedule. However, during the first few hundred miles of driving you can, by observing a few simple precautions, add to the future performance and economy of your car.

It is recommended that your speed during the first 500 miles be confined to a maximum of 60 M.P.H., but do not drive for extended periods at any one constant

speed, either fast or slow. During this period, avoid full throttle "jack-rabbit" starts and quick, abrupt stops.

Gentle braking during the first few hundred miles of operation will result in longer brake life and better future performance. Avoid hard stops especially during the first 200 miles of operation since brake misuse during this period will destroy much future brake efficiency.

Always drive at a moderate speed until the engine has completely warmed up.

DRIVING FOR ECONOMY

Proper maintenance and wise operation will combine to help you achieve maximum fuel economy with your Corvair. Your Authorized Chevrolet Dealer can properly tune and maintain your car but wise operation is your responsibility. Give the car sufficient warm-up

time, do not make "jack rabbit" starts or skidding stops, and drive at reasonable speeds and as steady as traffic permits to gain the benefits of all the economy built into your Corvair.

CAUTION: Carbon monoxide is a poisonous gas produced by the engine of any car. It is odorless, so you cannot detect its presence. Be safe. Never start or run engine in a closed garage.

STARTING THE ENGINE

IGNITION SWITCH

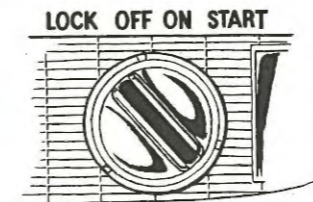

START—Used only when starting engine. When released, switch returns to ON.

ON—For normal operation after engine has been started.

OFF—Turns off engine and accessories.

LOCK—Same as "OFF" except that switch cannot be moved into or out of this position without ignition key. Always switch to LOCK and remove the key when leaving your car unattended.

NOTE: Key cannot be removed from switch when in OFF position, thus guarding against accidentally leaving switch OFF but not locked. The key may be removed when the switch is in LOCK or ON position and the switch may be removed between OFF and ON positions without the use of the key.

STARTING

1. Place transmission in Neutral position.
2. **COLD ENGINE**—Depress accelerator pedal half way and release, and pull choke knob *fully out*.

WARM ENGINE—Depress accelerator pedal half way and hold.

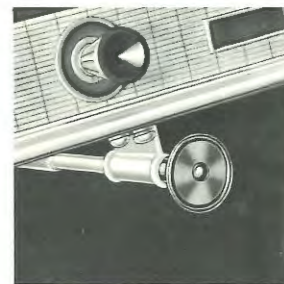

3. Turn ignition switch to ON. Release switch and accelerator pedal as soon as engine starts.
4. Adjust the choke position to obtain smooth engine operation. *As soon as engine will run smoothly without the choke, push the choke knob fully in.*

NOTE: The engine may be run at fast idle speed without choking, if desired, by pulling the choke knob out up to the first third of its travel.

MANUAL CHOKE

Your Corvair is equipped with a manual choke designed to give you full control of the vital function of engine choking. Since the choke operates to enrich the

fuel mixture delivered to the carburetors, its improper use can easily result in excessive fuel consumption. Therefore the choke should be used only as described above under "Starting". If, after the engine has become warm, the choke is still necessary to provide smooth operation, your authorized Chevrolet Dealer should be called upon to perform such engine adjustments as are necessary.

WARM-UP

Never race the engine or drive at high speeds until the engine has had a chance to warm up. Always drive at moderate speeds for several miles, especially in cold weather. Failure to allow sufficient warm-up time causes much unnecessary wear to the engine. Also, excessive speeds before axle and transmission lubricant becomes warmed up can cause harm to these parts.

DRIVING WITH THE MANUAL TRANSMISSIONS

The Three-Speed and optional Four-Speed Transmissions are operated in basically the same manner. Shift patterns differ, of course, as illustrated here. The white spots with black numbers on the speedometer face indi-

cate the speeds at which the optional 4-speed transmission should be shifted into 2nd, 3rd and 4th gear.

1st GEAR (LOW)—Depress clutch pedal, shift into 1st gear, slowly release clutch pedal while pressing on accelerator. As car gains speed, depress clutch pedal, release accelerator and move gearshift into 2nd gear.

2nd GEAR—Release clutch pedal and depress accelerator as above as car gains speed, then, in same manner as before, move gearshift lever into 3rd gear.

3rd GEAR (HIGH)—Slowly release clutch pedal and depress accelerator pedal. This is the cruising gear for all normal driving with the 3-speed transmission and with the 4-speed transmission at speeds below 56 mph.

4th GEAR (HIGH—4-speed Transmission Only)

Before speed reaches 56 mph, the transmission should be shifted, in the same manner, into 4th gear. This is the 4-speed cruising gear for speeds over 56 mph.

NOTE: It may be necessary to shift into 4th gear at speeds below 56 mph if the engine seems to be over-speeding in 3rd gear.

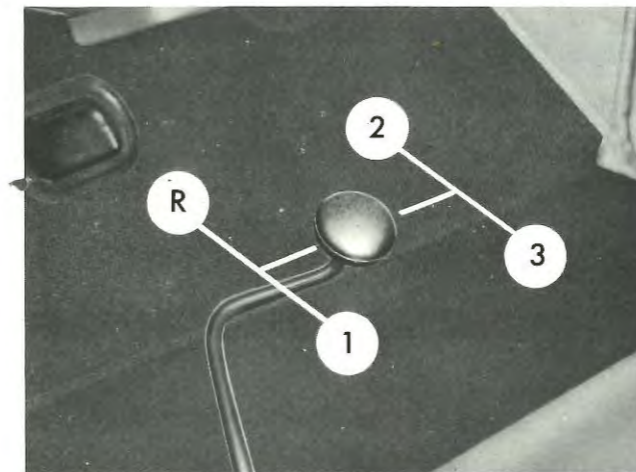

Three Speed Shift Pattern

TO STOP—Release the accelerator and depress the brake pedal. As car slows down, depress the clutch pedal and move the gearshift lever into Neutral.

NEUTRAL—For use when starting or idling engine.

REVERSE—Operate as for 1st Gear but always at a slow speed.

TOWING—Attaching points for lifting and towing are located in the front and rear bumper brackets.

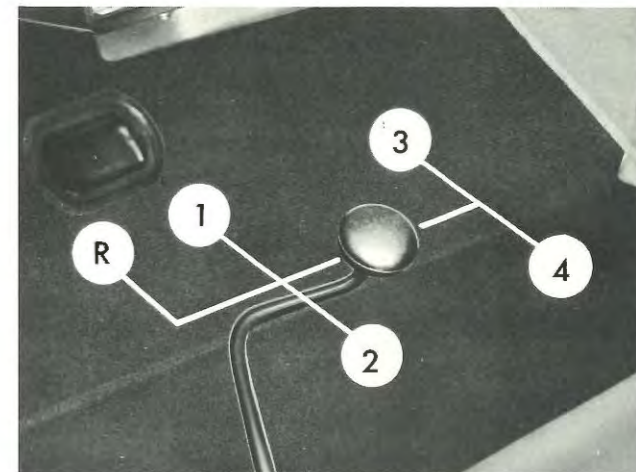

Four Speed Shift Pattern

PUSHING TO START

- Turn on key and depress clutch pedal.
- Place gearshift lever in Neutral position until car speed reaches 15 MPH.
- Move shift lever to 3rd position and slowly release clutch pedal.
- Never attempt to start the car by towing.

DRIVING WITH THE POWERGLIDE TRANSMISSION

The optional Powerglide transmission is a completely automatic transmission which replaces the standard clutch and transmission. After starting the engine with the selector lever in "N" (Neutral) position, merely select the range desired and depress the accelerator. The Powerglide transmission will do the rest.

During normal forward driving, the transmission starts in automatic low gear and will shift to cruising gear at some point between approximately 12 and 50 mph, de-

pending on the accelerator position. Thus, a gradual start with a steady, gradual increase of pressure on the accelerator pedal will enable the transmission to shift into the more economical cruising gear in the shortest possible time. Hard acceleration for fast starts will cause the transmission to remain in low gear for a considerably longer period with resultant higher fuel consumption.

When driving at speeds below 40 mph, the transmission may be shifted back into low range for extra accel-



OPERATING YOUR POWERGLIDE TRANSMISSION

POSITION	OPERATION	USES
R—REVERSE	For Backing Car (From Stopped Position)	
N—NEUTRAL	For Starting Engine (Brakes Applied)	NORMAL DRIVING RANGE
D—DRIVE	For all Forward Driving. Step hard on accelerator for extra acceleration below 40 MPH.	
L—LOW	For Hard Pulling at Low Speeds, Climbing, or Descending Steep Grades and for additional engine braking below 40 MPH.	SAND, SNOW, MUD OR ON STEEP GRADES

ation for passing by depressing the accelerator pedal fully. The transmission will automatically shift back into cruising gear when the accelerator pedal is momentarily released.

PUSHING TO START

- Pull choke knob out about $\frac{1}{3}$ of its length.
- Turn on key and move selector lever to Neutral. At 20 to 25 MPH move lever to "L."
- When engine starts, move selector lever to "D".

NOTE: Never tow to start.

TOWING

- Place selector lever in Neutral.
- If transmission or axle are malfunctioning, tow with rear wheels raised.
Never tow faster than 30 MPH.
- Attaching points for lifting and towing are located in the front and rear bumper brackets.

ROCKING CAR

When stuck in mud, sand or snow, you may rock the car forward and back by depressing the accelerator slightly and shifting the selector lever between "R" and "D." Avoid excessive engine speed while performing

When towing any vehicle on its front wheels, the steering wheel should be secured to maintain a straight forward position.

this operation.

WHEN PARKING CAR

It is important that when your Corvair 95 or Greenbrier is parked the parking brake be fully engaged. Do not count on the transmission in "L" or "R" to hold the car. Always engage the parking brake when parked.

POWERGLIDE DRIVING CAUTIONS

- Always engage parking brake when parked.
- Do not accelerate engine in L, D, or R with the brakes engaged. This can cause damage by overheating transmission.
- Do not hold car on an upgrade by accelerating engine. Use Brakes.
- Do not use Low position except for hard pulls at low speed, or climbing, or descending steep grades.
- Always stop car before shifting to Reverse.

All driving instruments are grouped in the instrument cluster which is located immediately in front of the driver to provide quick reading and a maximum of convenience and accessibility. The "Temp-Press" and "GEN-FAN" indicator lights provide important information concerning the condition of the engine and should be checked regularly during operation of the car. The information on these pages will help you understand the operation of these instruments and the illustrations here and on page 10 will acquaint you with the instrument cluster and the instrument panel as a whole.

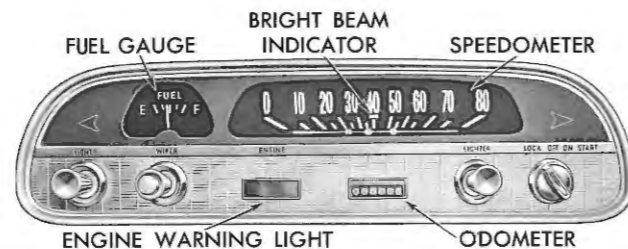

FUEL GAUGE



This gauge indicates fuel quantity in the tank only when the ignition switch is in the "ON" position. When the ignition is "OFF," the indicator pointer will not necessarily return to the EMPTY mark, but may stop at any point on the gauge.

SPEEDOMETER

Shows speed in miles per hour. The odometer below the speedometer registers accumulated mileage.

Information concerning the four speed transmission shift points indicated below will be found in the manual transmission operating instructions on page 4.



"TEMP-PRESS" AND "GEN-FAN" INDICATORS

These indicators are extremely important since they provide a constant check on the operating condition of the air cooled engine and the generator of your Carvair 95. Both indicator lights should light with the ignition switch "ON" and before starting the engine. Indicator lights will go out shortly after engine is started and during normal operation of the car. Flickering of the "Gen-

Fan" light while engine is idling is a normal condition.

Engine cooling depends on operation of the fan driven by the Gen-Fan belt. A broken or slipping fan belt will cause the Gen-Fan indicator to remain lighted during normal operation and continued engine operation can result in serious damage.

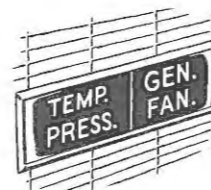

INDICATOR REMAINING LIGHTED DURING NORMAL OPERATION	PROBABLE CAUSE	ITEMS TO BE CHECKED
TEMP-PRESS Indicator	Low Oil Pressure	Engine Oil Level
	Excessive Engine Temp.	Oil Level and Fan Belt
GEN-FAN Indicator	Generator Not Charging	Generator
	Fan Not Operating	Fan Belt

IMPORTANT:

If either of the indicators light during normal operation, STOP CAR IMMEDIATELY and turn off ignition. Check for a broken or slipping fan belt or low engine oil level. NEVER DRIVE CAR UNTIL BROKEN FAN BELT IS

REPLACED. Never drive car when "Temp-Press" indicator is lighted. Car can be driven at slow speeds if only "Gen-Fan" indicator is lighted and fan belt is not broken, however, generator must be checked and serviced as soon as possible.

CONTROLS

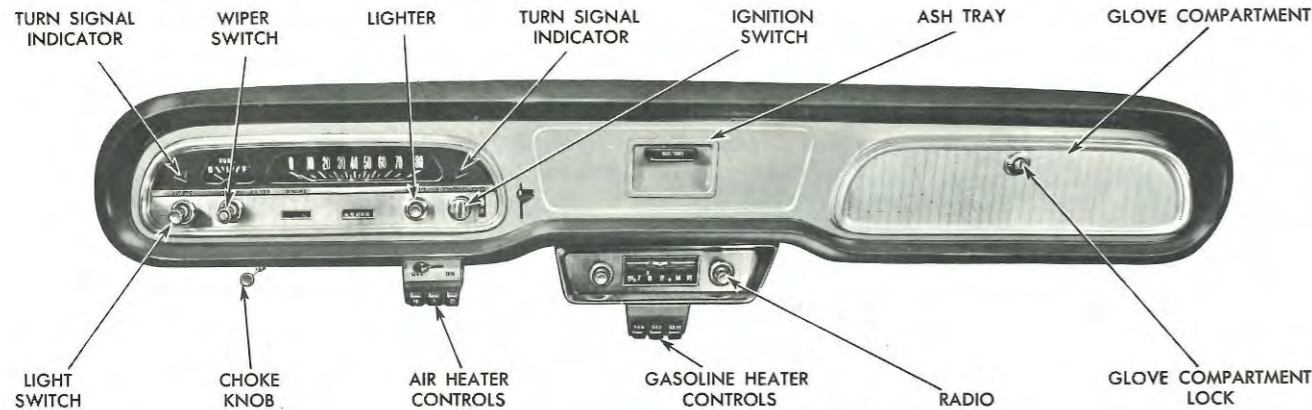

LIGHT CONTROL KNOB

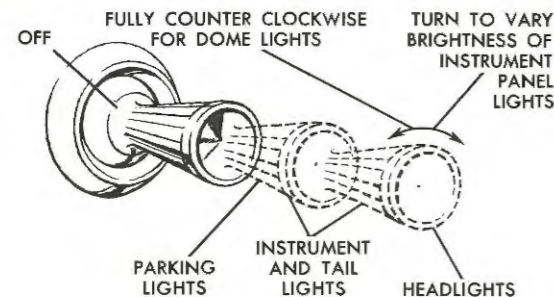

The three-position light switch is operated as shown. Turn the knob to vary the brightness of the instrument lights. Turn fully counter-clockwise past the "detent" to turn on the dome light. Headlamp and parking lamp circuits are protected by a circuit breaker. An overload condition will cause the headlights to "flicker" on and off. Your Authorized Chevrolet Dealer should remedy this condition at once.

CHOKE CONTROL

Operation of the manual choke knob is fully described on page 3.

DIMMER SWITCH

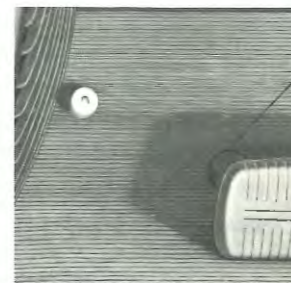
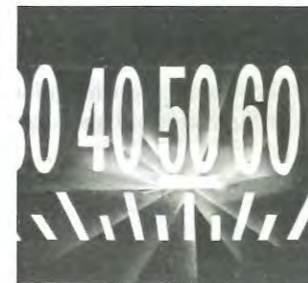

The foot button switches the headlights between "high" and "low" beam. The "high" beam indicator will be lighted when the headlights are on "high" beam. Always dim the lights when approaching oncoming cars.

TURN SIGNAL

The turn signal lever should be moved UP to signal a right turn or DOWN to signal a left turn. The indicator lights in the instrument panel will signal the direction as will the parking and tail lights. When the turn is completed, the lever will automatically return to neutral position.

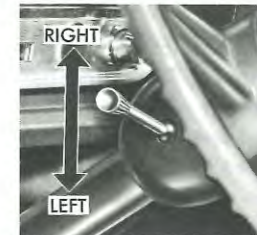

SAFETY HINT: Use the turn signal light when stopped beside the highway at night. Ignition switch must be "on."

LIGHTING SYSTEM TROUBLE CHECKS

- If headlights flicker on and off rapidly, your Authorized Chevrolet Dealer should be called upon immediately to correct the overload condition.
- If the tail light fuse blows out, the instrument panel lights will also be inoperative. Check both the instrument panel fuse and the tail light fuse. (See page 39.)
- If, when signalling a turn, the indicator light comes on but does not flash, a burned out parking or tail lamp on that side or an improper flasher (3-bulb instead of

2-bulb flasher) is indicated.

- If the turn indicator comes on and stays on but does not flash when signalling a turn in either direction, and no "clicking" is heard, replace the flasher.
- If flasher clicks but the indicator light does not operate, replace the indicator bulb.
- A series type 2-bulb flasher is standard equipment on Corvairs. Always replace with the same type flasher.

FOOT CONTROLS

Foot controls consist of the dimmer switch (the operation of which is covered on page 11), the clutch pedal (manual transmissions only), the brake pedal and the accelerator pedal.

CLUTCH PEDAL

The operation of the clutch pedal has been fully covered under "Driving with the Manual Transmissions" on page 4. Its operation is the same whether your car is equipped with the 3-speed or the 4-speed transmission. Excessive clutch wear can be caused by letting up the clutch abruptly rather than smoothly, and by "riding" the clutch—that is, letting your foot rest on the clutch while driving.

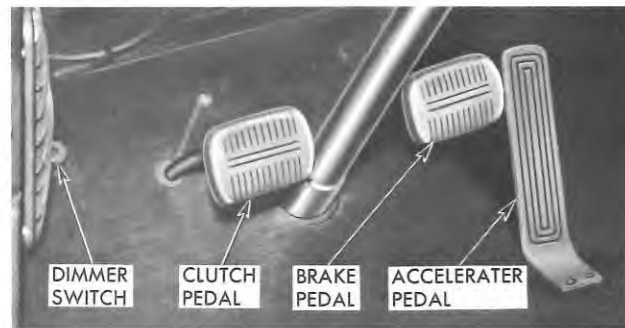

BRAKES

The brake pedal should have a hard firm feel when applied. If the pedal feel becomes soft or spongy the brakes are in need of service. Your Authorized Chevrolet Dealer can return your brakes to their original safe operating condition.

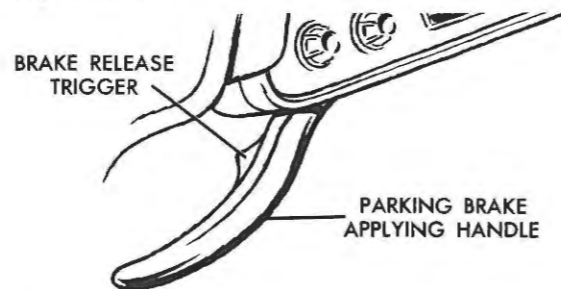

PARKING BRAKE

Pull the parking brake lever to engage the brake. The lever will remain in the applied position until released by means of the "trigger" on the handle. To release, pull the handle toward the steering wheel, depress the unlocking trigger and allow the handle to return to the released position. Always engage the parking brake when parked.

The accessory brake alarm light is very useful in warning you that your parking brakes are applied.

WINDSHIELD WIPERS AND WASHERS

The single speed (or optional two-speed) parallel acting wipers are operated by means of the wiper control knob on the dash. Turning clockwise on this wiper control knob will start the wiper motor. The optional two speed wipers have two switch positions, "Low" and "Hi". A fully counter-clockwise turn of the knob turns off either wiper.

Exposure to the elements tends to "wear out" the rubber in the wiper blades. Check the blades periodically and replace them whenever they show signs of streaky or otherwise poor wiping action.

Pressing once on the accessory windshield washer button will cause the washer to squirt a measured amount of water or other cleaning agent onto the glass and will at the same time turn on the wiper motor. The wiper must then be manually turned off, when the washing process is completed, by means of the wiper control knob.

Water or cleaning agent needed for operation of the accessory windshield washers is carried in a plastic water bag under the dash panel. It is attached by means of three hooks to the fire wall. To fill with water or solvent: remove the bag from the hooks, drop to where the cap

may be unlocked and removed, fill the bag, replace the cap and reinstall on the three hooks. Keep the washer bag filled with a solution of water and a suitable solvent. G. M. Part No. 988299, Windshield Washer Anti-Freeze and Solvent, is recommended for use in the Corvair windshield washer bag. NEVER USE ANY SOLVENT OR ANTI-FREEZE SOLUTION WHICH CONTAINS METHANOL. Fill the washer bag only $\frac{3}{4}$ full for expansion if the solution freezes. In freezing weather, pre-warm the windshield using the heater defrosters before using the washers.

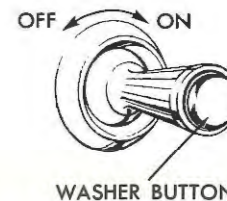

GASOLINE HEATER

The accessory Corvair gasoline heater is designed to provide an ample volume of outside heated air within two minutes after being turned on.

Three control levers provide full control of the gasoline heater.

FAN—this is the AIR-ON control and the blower control. This lever must be pushed down before the unit will operate. The three-speed switch provides "LOW" blower speed at its first stop, "INTERMEDIATE" speed at the second stop and "HI" blower speed when in the full down position.

DEF—diverts heated air to the defroster ducts for defogging or deicing windows.



HEAT—Allows for selecting degree of heat desired. Heater will begin to supply heat in a minimum of 30 seconds. For efficient heating and heat distribution, keep all windows closed.

NOTE: When heater or ignition switch is shut off, the combustion blower will continue to operate for 30 to 40 seconds to remove unburned fuel and vapor from the system. This is normal for this type of heater.

TYPICAL HEATER CONTROL SETTINGS

SEASON	SERVICE DESIRED	FAN	DEF	HEAT
WINTER DRIVING	Normal Heating	On	Off	As Required
	Winter Defrost	On	On	As Required
	Winter Defogging	On	On	As Required
SUMMER DRIVING	Summer Defogging	On	On	Off

DIRECT AIR HEATER



The Direct Air Heater makes use of engine cooling air to heat the interior of the car. After performing its engine cooling function the air is channeled through a blower and on into the car. When the AIR and HEAT controls are in the OFF position the engine heat is ducted to the rear of the engine and out through the thermostatically controlled engine cooling doors.

The heater controls, similar to those of the accessory gasoline heater, described on the previous page, provide full control over the heater system.

FAN—The three speed fan lever controls the blower which forces the heated air into the passenger compartment.

HEAT—This lever operates a diverter door in the heater assembly which controls the temperature of the air delivered to the passenger compartment by mixing cool air with the heated air from the engine in the desired proportion. This provides an almost infinite variation of air temperature control.

AIR—The air lever controls the cold air diverter door in the heater assembly which controls the flow of cool air to the mixing compartment necessary for temperature control.

DEF—The defroster lever controls the diverter door which blocks off the flow of air to the front compartment floor inlets and allows it to flow to the defroster outlets.

Any odor of objectionable fumes in the passenger compartment with heater on or off may be caused from oil having dripped or having been spilled onto the engine shrouding or by a faulty gasket or seal. To avoid any discomfort the cause of any such odor should be traced immediately and any defect promptly corrected.

CHEVROLET RADIOS

Each of the optional Chevrolet Radios will give you the same powerful, undistorted reception. The radios differ mainly in their operating controls which are reviewed here.

Manually Tuned Radio

RIGHT HAND KNOB—The outer knob manually selects radio stations.

LEFT HAND KNOB—The outer knob turns the set on and off and controls the volume.

The inner "wing knob" may be moved to change the tone from treble (extreme clockwise) to bass (extreme counterclockwise).

This control is designed to give the highest tone fidelity when positioned at the midpoint between the treble and bass settings.

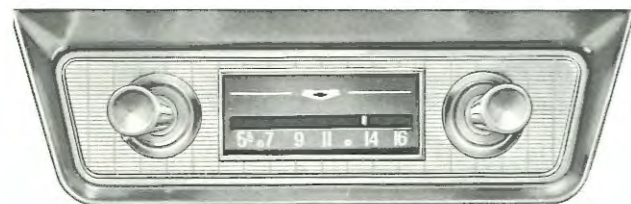

Push Button Radio

The push button radio has the manual tuning control knobs plus push buttons which automatically select preset stations when pushed in.

To preset the push buttons:

1. Warm up the radio for 10 minutes (20 minutes in freezing temperatures).
2. Pull the push button straight out as far as it will go.
3. Tune the desired station manually.
4. Push the button all the way in.
5. Check operation of push button and repeat Steps 1 through 4 if tuning is not accurate.
6. Repeat this procedure for each push button.



RADIO TIPS

- Be sure your dial is exactly on the station for clearest reception.
- For local reception, raise the antenna at least as high as the roof of the vehicle. For long distance reception, extend the antenna to its full length.
- Push buttons may need to be readjusted occasionally for best reception.
- The Conelrad markings at 640 and 1240 on the radio dial indicate Office of Civilian Defense frequencies; the only frequencies which will be used in case of a national emergency.
- If radio stops playing, first check the radio fuse in the junction block; then check the antenna lead-in cable. If this does not locate the trouble, take the radio to your Authorized Chevrolet Dealer.

CIGARETTE LIGHTER AND ASH TRAY

Press in on the optional cigarette lighter to heat. When ready for use, it will "pop" out. The ash tray cover slides toward the front of the car to open. The ash receptacle lifts out for cleaning.



AIR VENTS

Additional summer ventilation is provided through vent inlets in each side of the front passenger compartment. The vents may be opened or closed by means of the control knobs beneath each end of the instrument panel.



KEYS



KNOCK-OUT PLUG

A single key operates all the locks on your Corvair 95 or Greenbrier, both front doors, the double side doors, rear doors, ignition switch and glove box.

Each key has a serial number stamped on a removable plug. This number will enable you to have another key made in the event that the original is lost.

To avoid the possibility that unauthorized persons might duplicate your key, it is strongly recommended that you record the serial number and then, with a hammer and punch, remove the knockout plug.

DOORS AND LOCKS

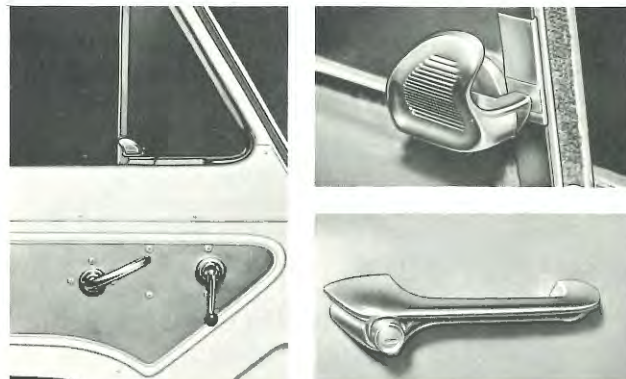

Both front doors may be locked from the outside by means of the ignition key inserted into the push button in the door handle. Turn the key clockwise to lock, counter-clockwise to unlock.

Lock the front doors from the inside by pushing fully forward on the release handles. Unlock and open the doors from the inside by pulling fully rearward on the release handles.

The ventipane window friction locks are simply lifted up and forward to unlock and the pane pushed out to the desired position.

DOUBLE SIDE DOORS

FRONT SIDE DOOR — Open from the outside by turning the handle downward and from the inside by pulling to the rear on the inside release handle.

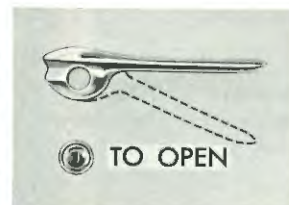

REAR SIDE DOOR—Open (after the front side has been opened) by means of the release handle located on the inner side face.

LOCKING THE SIDE DOORS —After both side doors are closed they may be locked from the outside by means of the key lock and from the inside by means of the locking knob. Turn the knob counter-clockwise to unlock, clockwise to lock. Inner and outer door locks operate separately. Therefore if a door is locked from the outside, for instance, it cannot be unlocked from the inside.



The front side door may be key locked while open and, when closed, will remain locked.

DOUBLE REAR DOORS

The rear doors operate in much the same manner as the side doors, but lock and unlock at the door handle push button release only. No inner door locking mechanism is provided for the rear doors.



FULL DOOR OPENING FEATURE

Special door checks normally permit each side and rear door to open to a maximum of 95°. By removing these checks from their retaining slots in the doors, a full 180° opening of each of these doors is possible. When the doors are closed the check automatically enters its slot in the door thus setting the door for its normal 95° opening.

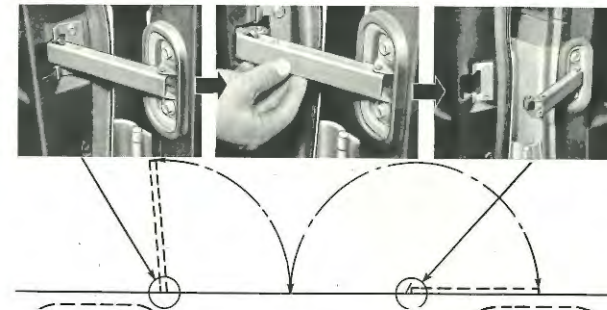

RAMPSIDE



The Rampside pickup differs from the Loadside pickup only in the rampgate in the right hand side of the body. The rampgate provides convenient, safe and rapid loading and unloading from the curb side of the vehicle.

To Open

- Pull up on the locking ring located inside the pickup box and to the left of the gate.
- Lift up on both release handles, recessed in the gate inner panel, and *carefully* lower the gate to level ground.



inner panel, and *carefully* lower the gate to level ground.

To Close

- Carefully lift the gate from the ground and firmly slam to close.

TAILGATE

The tailgates in the Rampside and the Loadside pickups are identical. Open the tailgate by lifting up on both release handles recessed in the inner panel. Slam firmly to close.

SEATS

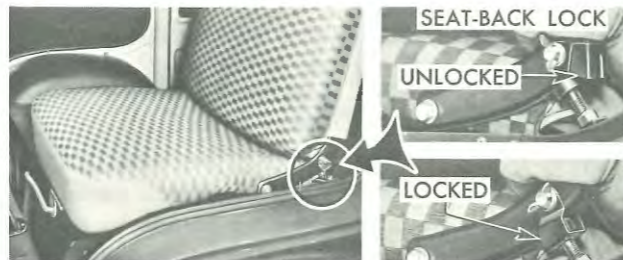

- Adjust the front seat fore and aft by means of the adjuster handle shown.
- If desired, the seat back may be adjusted to lean farther forward or backward by means of the bolt and the lock nut shown.
- Adjustment of the seat back lock determines whether the seat back will be rigid or will fold forward. With the seat back lock in the down position, the seat back will not fold forward.

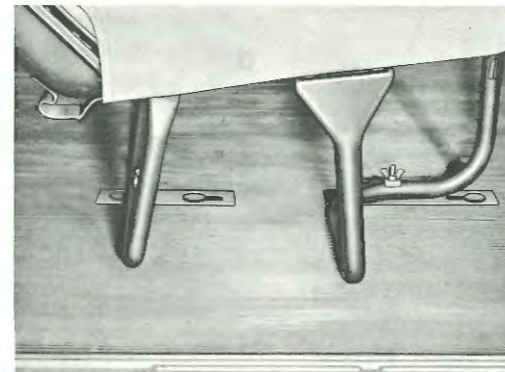
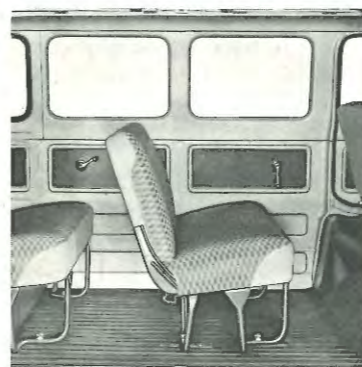

SECOND SEAT

The Greenbrier second seat assembly is factory installed in the back of the rear compartment in the optional third seat position.

If desired the seat may be moved from this position to either a forward or backward seat position. The seat may be changed whenever desired.

An optional third seat is available if desired, but can be mounted only in the third seat position.

If desired, all rear compartment seats may be quickly and easily removed to provide additional cargo space.

To Move Seat

- Remove the proper knock-out plugs from the floor mat after deciding whether, in the second seat position, the

seat is to face forward or rearward. This will expose the mounting slots.

- Loosen the wing nuts attaching the front legs of the second seat to the floor and slip the bolt heads rearward out of the retaining slots.
- Move the seat to the desired position, unfold the rear leg and slide the four bolt heads into the slots and tighten the wing nuts.

FUEL FILLER CAP

The fuel filler cap is located below the rear of the driver's door.

CLEANING HINTS

EXTERIOR APPEARANCE

WASHING YOUR CORVAIR

The best way to preserve the original beauty of the finish of your Corvair is to keep it clean. Calcium chloride and other salts, road tar, excretion from insects, tree sap, chemicals from factory chimneys and other foreign matter may permanently damage both paint and bright metal parts. Regular, frequent washings and a thorough cleaning after exposure to any of the above is recommended. Wash the car in either warm or cold (never hot) water; never in the direct rays of the sun; and always wait until the sheet metal surfaces have cooled before beginning. Never wipe off dust and dirt when surfaces are dry because this may scratch the finish.

POLISHING YOUR CORVAIR

Your Corvair is finished with Magic Mirror Acrylic Lacquer. A thorough washing is generally all that is required to maintain a "new car" appearance. However, if the car is to be polished make certain that the label of the cleaner or polish used states that the product is suitable for use on acrylic lacquer finishes. All G. M. cleaners and polishes are suitable for use with acrylic finishes. Any tar or road oil remover used should indicate

on the label that it is harmless to Acrylic finishes. G. M. and Tar Road Oil Remover has been especially compounded for this purpose.

PROTECTION OF EXTERIOR BRIGHT METAL PARTS

All bright metal parts of the car should be regularly cleaned and protected against the same substances harmful to the painted surfaces. Normally, washing with water is all that is required. However, G. M. Chrome Polish may be used on CHROME or STAINLESS STEEL trim if necessary. Use special care with ALUMINUM trim. Never use auto or chrome polish, steam or any caustic soap to clean aluminum. Wash only with lukewarm water, and if necessary, a mild soap. Rinse well and dry thoroughly.

It is recommended that all bright metal parts of your Corvair, after being thoroughly cleaned, be given a coating of wax and rubbed to a high polish. This will serve to keep corrosive agents away from these surfaces, and should be repeated as often as required.

CLEANING WHITE SIDEWALL TIRES

Use soap, warm water or a tire cleaner such as G. M. Whitewall Tire Cleaner and a stiff brush to remove

road grime and dirt from the white sidewall tires. A fine grade of steel wool will remove severe curb scrapes. Do not use gasoline, kerosene or any oil product which would discolor or deteriorate the rubber.

CAUTION: Some white sidewall cleaners will cause serious damage to aluminum trim. Use caution when cleaning tires with this type of cleaner. G. M. Whitewall Tire Cleaner is safe to use around aluminum trim.

BRIGHT METAL TRIM— TYPE AND LOCATION

ALUMINUM	Headlight Frames Parking Light Frames Tail Light Frames Front Grille and Ornament
CHROME	Push-Button Door Handles Key Locks—All Doors Front Door Nameplates (Greenbrier Only)
STAINLESS STEEL	Windshield Wiper Arms

INTERIOR APPEARANCE

DUST AND DIRT

Clean the interior of your car frequently, using a broom or vacuum cleaner. A damp cloth will wipe dust from hard surfaces. G. M. Leather Cleaner is available from your Authorized Chevrolet Dealer to clean any imitation leather, vinyl or coated trim fabric on seats or door panels.

SPOTS AND STAINS

Remove upholstery stains as soon as possible or they may become "set" and difficult or impossible to remove. First determine the type and age of the stain and the kind of upholstery material. Kar Kleen Upholstery Cleaner or Kar Kleen Upholstery Spot Cleaner, available from your Authorized Chevrolet Dealer, will remove most stains. For oil, grease and road grime stains not removed by these cleaners the use of a volatile type cleaner such as G. M. Upholstery Spot Remover is recommended. Do not use alkaline cleaners for they may damage the color or finish of the materials. Other solutions such as hot or cold water, ammonia water, soap, ink eradicator, etc., will probably discolor and disturb the material.

OCTANE REQUIREMENTS

If you plan to operate your Corvair 95 or Greenbrier outside the continental limits of the United States or Canada, there is a possibility that the best fuels available are so low in octane quality that excessive knocking and serious engine damage may result from their use. To minimize this possibility, write to Chevrolet Motor Division, General Motors Corporation, Service Technical Department, Detroit 2, Michigan giving:

- The compression ratio of your engine (refer to Specification Section—Page 38 in this booklet).
- The car identification number (obtain from car registration or title).
- The country or countries in which you plan to travel.

You will be furnished details of adjustments or modifications which should be made to your engine, by your Chevrolet dealer prior to your departure. Failure to make the necessary changes to your car and subsequent operation under conditions of continuous or excessive knocking, constitutes misuse of the engine for which the Chevrolet Division is not responsible under the terms of the Warranty.

After arriving in a foreign country, contact the nearest authorized General Motors dealer for brand names of the best fuels available and advice as to where they may be purchased.

ENGINE LUBRICATION

LOWEST ANTICIPATED TEMP.	RECOMMENDED SAE VISCOSITY OIL	
	SINGLE VISCOSITY	MULTI-VISCOSITY
32° F.	SAE-30	SAE-10W-30
-10° F.	SAE-10W	SAE-10W-30
Below -10° F.	SAE-5W	SAE-5W-20

Always use SAE 30 if daytime temperature is above 60° F.

After the first 1,000 miles of driving, if average daytime temperature is below 60° during the break-in period, the original heavy duty break-in oil should be drained from the engine and the crankcase refilled with oil as shown in the accompanying table.

If average daytime temperature is above 60°F. during the break-in period, change initial break-in oil to SAE 30 oil after the first 500 miles of operation.

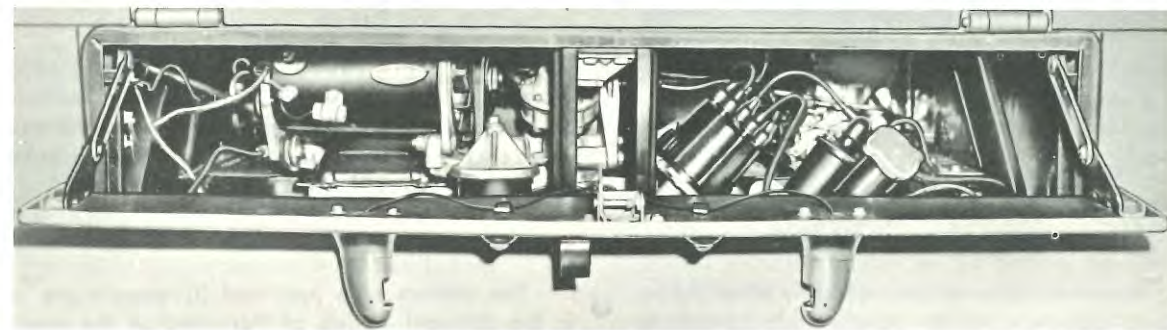

Every 4000 miles thereafter, under normal operating conditions, drain and refill the crankcase in the same manner. Adverse driving conditions; such as extreme dust conditions or short trip winter driving (less than 1,000 miles per month) makes it advisable to change oil every month. Similar short trip driving in the summer makes it advisable to change oil every two months.

For maximum protection under all driving conditions, it is recommended that you use oil designated "For Service MS" or "For Service DG" in your Corvair.

Check the oil level on the dipstick frequently. The level should be somewhere between the "add oil" and "full" marks on the dipstick. Do not overfill. The oil filter element should be changed after the first 5000 miles of driving and every 4000 miles thereafter, more often under adverse driving conditions.

COOLING SYSTEM CARE

The Corvair engine, being an air cooled engine, is entirely dependent on the fan belt and blower to supply sufficient volume of air for cooling purposes. The engine fan belt should be checked for tightness at regular intervals and replaced when necessary. Watch the "Temp-Press" and "Gen-Fan" indicator lights on the instrument panel for signs of possible engine overheating.

The engine air inlet louvers are located in each side of the car just above the rear wheels. Since these louvers supply all of the engine combustion and cooling air, care should be taken that they are never sealed or blocked.

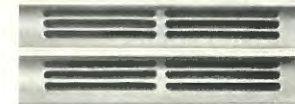

TIRE CARE

All models of the Corvair 95 and Greenbrier Sportswagon are supplied with 7.00 x 14-4 ply tubeless tires as standard equipment. Optional 7.00 x 14-6 ply tires are available for heavier duty.

All models are designed to operate most efficiently with the inflation pressure shown in the following tables. Nothing will be gained by exceeding pressure shown, whereas, excessive pressures can adversely affect riding comfort and quietness. Under inflation affects vehicle handling and tire life. Over-steer problems may also be encountered with incorrect pressure. Maintain the recommended inflation pressures at all times.

All four wheels of your Corvair have been static-balanced for best performance and tire life. Wheels should be rebalanced after tire service or replacement.

TIRE INFLATION PRESSURES

TIRE SIZE	COLD	HOT
7.00 x 14-4	24	28
7.00 x 14-6 (optional)	28	32

Cold—After car has been parked for 5 hours or more or driven less than one mile.

Hot—Pressures can raise as much as 5 pounds above cold figures depending on loads carried, length of driving, and car speed prior to check.

Inspection and Repair

Inspect every 1000 miles for puncturing objects in the tires. If any are found, do not attempt removal until you are in a position to change the tire or have it repaired. Also, check regularly that the wheel rim has sustained no damage which could affect the air seal.

Jacking the Car

The scissors type jack and its wrench are stowed in the different models as illustrated on the next page. The opposite end of the wrench is shaped into a "finger" designed for use in removing the hub caps.

When jacking the car, set the hand brake, block

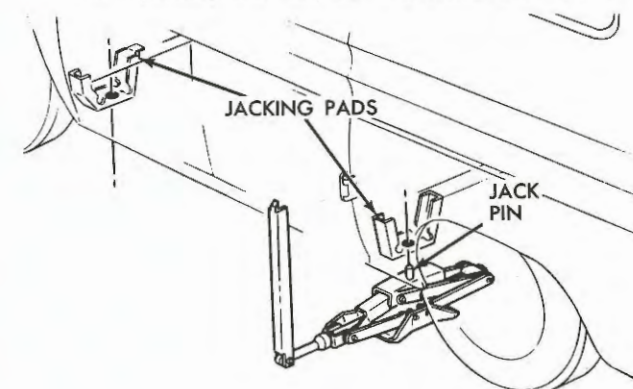

diagonal wheel, and, if changing wheels, remove the hub cap and loosen wheel nuts. Place the jack under the side of the car located as shown on the previous page.

CAUTION: Never attempt to raise the Corvair by placing any kind of jack under the bumper.

SPARE TIRE AND JACK STOWAGE

Spare tire and jack stowage are illustrated below.

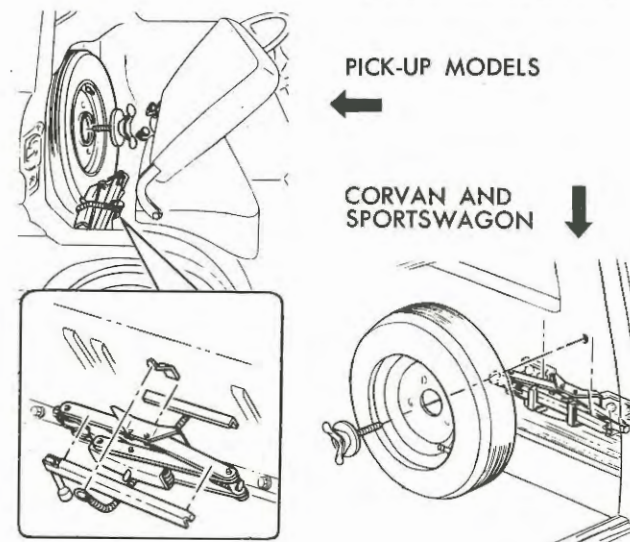

FOR MAXIMUM TIRE LIFE

- Keep tires properly inflated.
- Check regularly for cuts, bruises and puncturing objects. Nails etc. will often be carried in the tire with no noticeable loss of air. Do not remove a puncturing object until prepared to change or repair the tire.
- Avoid sudden starts and stops; take curves and corners slowly.
- Avoid driving over curbs, sharp objects or chuckholes.
- Have wheel alignment checked periodically, especially when tires show unusual wear.
- Rotate the tires as shown below every 5000 miles.

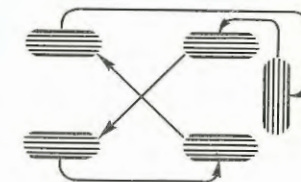

SWITCHING
TIRES

CHASSIS LUBRICATION

Your Corvair deserves the best care you can give it. Regular maintenance will guarantee you more, dependable, trouble free miles of enjoyable driving. The following pages are devoted to maintenance and lubrication items which should be performed at regular intervals. Each item is numbered to correspond to the items shown on the Lubrication Diagram on page 35. The Lubrication and Maintenance Guide on pages 36 and 37 provides an easy way of checking on necessary maintenance at any given mileage or seasonal interval.

ENGINE COMPARTMENT ACCESS

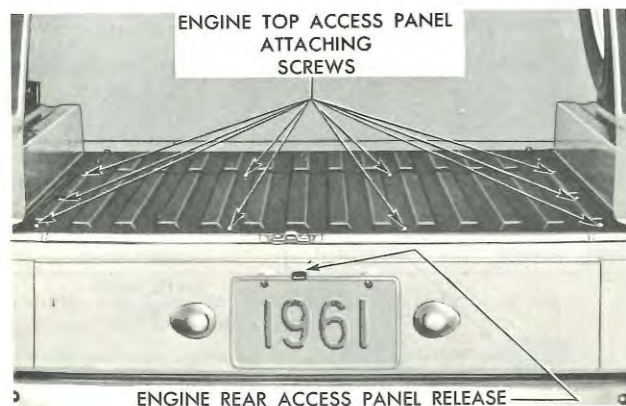

1. CRANKCASE LUBRICATION

When checking or adding oil, be careful to avoid spilling or dropping oil onto the engine shrouding. This may result in objectionable fumes entering the passenger compartment when the optional Direct Air Heater is installed.

First 500 miles (if temperature has been over 60°F.)
Change as per table on page 24.

First 1000 miles (if temperature has been below 60°F.)
Change as per table on page 24.

Every 4000 miles thereafter during favorable driving conditions (over 10 miles per trip).
Change as per table on page 24.

During adverse driving conditions or short trip driving (less than 10 miles per trip).
Winter—Change every month.
Summer—Change every two months.

2. OIL FILTER

Change the filter element after the first 5000 miles of operation, and every 4000 miles thereafter.

NOTE: When changing the filter element, be careful not to drip oil on the engine fan belt.

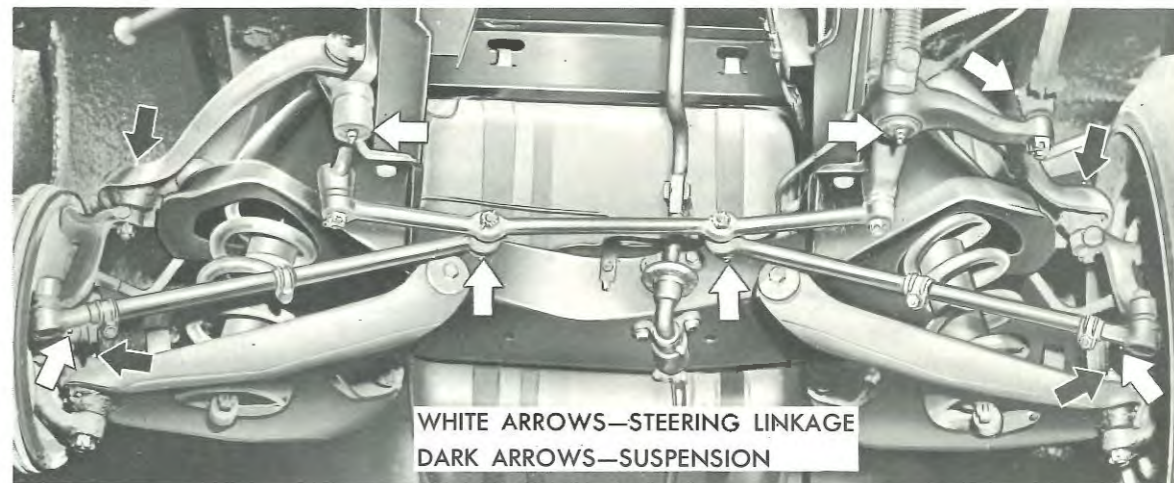

3. FRONT SUSPENSION

Every 1000 miles—Lubricate 4 fittings shown above with chassis lube.

4. STEERING LINKAGE

Every 1000 miles—Lubricate 7 fittings shown above with chassis lube.

5. STEERING GEAR

Every 1000 miles — Remove the filler plug and check to see that the lubricant is at the level of the filler plug hole. If necessary, add steering gear lubricant to level of the filler plug hole.



6. GENERATOR



Every 1000 miles—Fill both oilers with light engine oil. Do not over oil the oiler nearest fan belt.

7. DISTRIBUTOR

Every 1000 miles—Fill hinged cap oiler with light engine oil.

Every 5000 miles—Apply small drop of light engine oil to breaker lever pivot. Apply Delco Ball Bearing and Cam Lubricant or a high melting point wheel bearing lubricant to the cam surface.

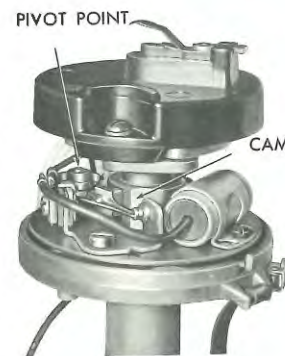

8. AIR CLEANER

The Corvoir engine is equipped with two air cleaners, one on each carburetor. Remove each air cleaner

cover after snapping the wire cover retainer rearward and removing the cover retaining wing nut. Service each filter element as follows:

Every 2000 miles—Clean and re-oil filter elements. Under severe dust conditions, it may be necessary to clean and re-oil the elements more often. To clean: remove element from screen, wash in kerosene or mineral spirits to remove oil and dirt. Squeeze dry, dip in engine oil and squeeze to remove excess oil. (Never shake or wring—always squeeze.)

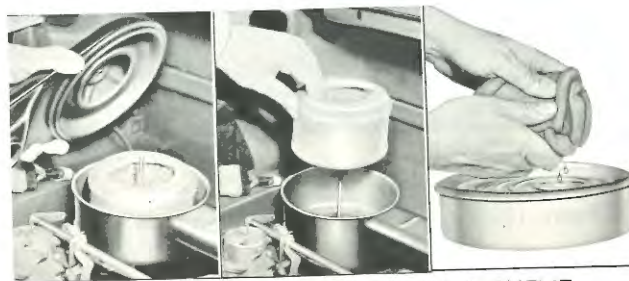

REMOVAL AND CLEANING OF ELEMENT



AIR CLEANER LOCATION

Replace in screen assembly and reinstall in Air Cleaner.

NOTE: A clean air cleaner element is essential to satisfactory gas mileage.

9. ENGINE OIL COOLER

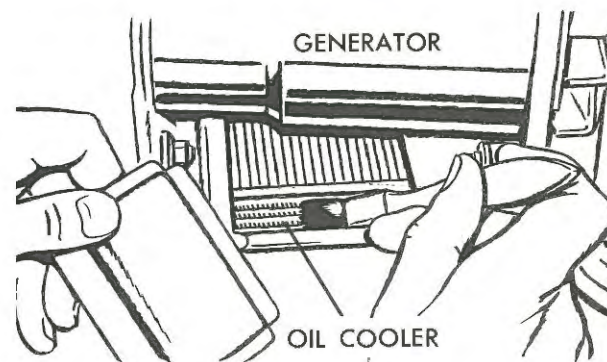

Every 5000 miles—Remove cover and brush or blow out accumulated dirt.

NOTE: Material usually found in the oil cooler consists primarily of twigs, straw, chaff, and leaves. Check the cooler more often if you drive in areas where such material is more likely to enter engine compartment.

10. FRONT WHEEL BEARING

Every 10,000 miles—Clean and repack bearings with a high melting point lubricant. Replace grease seals at the same time.

When operating under dusty or other adverse driving conditions, the front wheel bearings should be checked more often and serviced when necessary.

11. UNIVERSAL JOINTS

Every 25,000 miles—clean and repack the universal joints with a high melting point lubricant. If the vehicle has been operated during extremely dusty or otherwise adverse driving conditions, the universal joints should be checked and, if necessary, serviced more often.

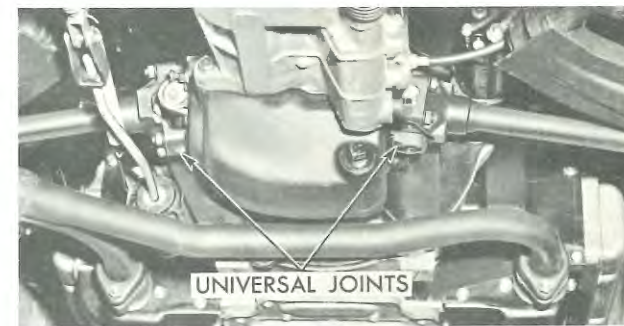

12. TRANSMISSION

3 and 4-Speed (Transmission and Rear Axle)

Follow recommendations given under "Rear Axle".

3 and 4-Speed Control Linkage

Every 1000 miles—Lubricate the two fittings located at the forward end of the transmission control rod with chassis lube. The fittings are illustrated at the right.



Powerglide (Transmission only)

Every 1000 miles—Check fluid level on dipstick located in the right front of the engine compartment, with engine idling, selector lever in NEUTRAL position, parking brake set and transmission at operating temperature. Add Automatic Transmission Fluid Type "A" with an AQ-ATF-A mark to full mark on dipstick. Check with en-

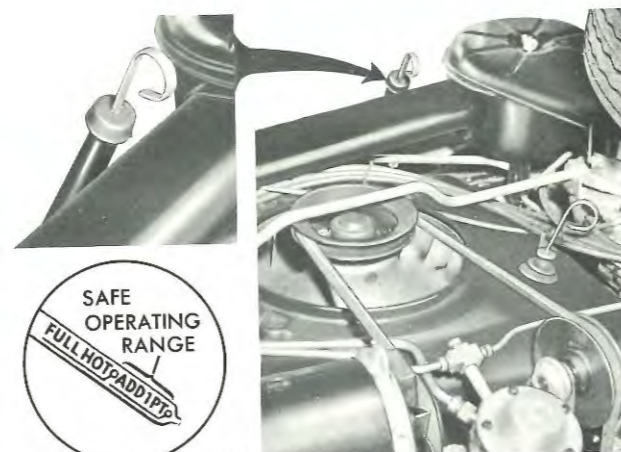

POWERGLIDE DIPSTICK

gine idling. **DO NOT OVERFILL.** Correct oil level must be established by dipstick measurement.

Add small amounts of oil, checking the level after each addition, until the proper level is reached.

NOTE: From the "Add Oil" mark to the "Full" mark on the dipstick indicates a difference of only 1 pint of fluid.

Clean dust and dirt from transmission oil cooler (reached through battery access door) periodically.

13. REAR AXLE

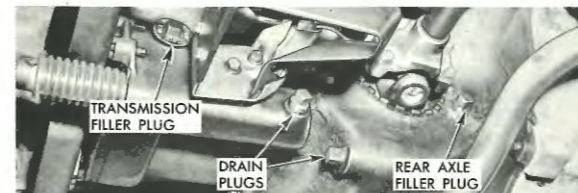

First 1000 miles and every 10,000 miles or seasonally—Drain rear axle only (Powerglide) or both rear axle and transmission (3-speed). Refill all units drained with lubricant specified below.

Every 1000 miles—Check rear axle at operating temperature and keep lubricant at level of filler plug. If rear axle lubricant is below safe limit, check 3-speed lubricant level also. Keep filled with lubricant specified below.

Rear Axle Lubricant

Refill rear axle and 3-speed transmission as described above with G. M. No. 3772661 (SAE-80 Multipurpose Gear Lubricant) or equivalent.

NOTE: if rear axle requires additional lubricant, be sure that 3-speed transmission is also checked. Low lubricant in the axle indicates that the transmission may also be low.

14. BATTERY

Every 1000 miles—Check fluid level. Keep filled with distilled water to level of the split ring in the vent tube. Oil battery terminal washer with engine oil. Clean top of battery regularly with diluted ammonia or soda solution and flush with clear water. Check state of charge regularly, especially in freezing weather, for an undercharged battery may freeze and break.



15. FUEL FILTER

Every 15,000 miles—Replace filters, located in each carburetor inlet. If flooding occurs, replace more often.



16. BRAKE MASTER CYLINDER

Check frequently and maintain fluid at mark inside reservoir below filler opening, using G.M. Hydraulic Brake Fluid, Super No. 11. If addition of fluid is required more often than every 1000 miles the entire system should be checked for leaks.



17. CLUTCH AND BRAKE PEDALS AND CLUTCH LINKAGE

Every 1000 miles—lubricate the fitting at the pivot point of each pedal with chassis lube.
 Every 5000 miles—coat the exposed clutch linkage (located just ahead and to the right of the 3 and 4 speed transmission) with Lubriplate.

LUBRICATION AND MAINTENANCE DIAGRAM

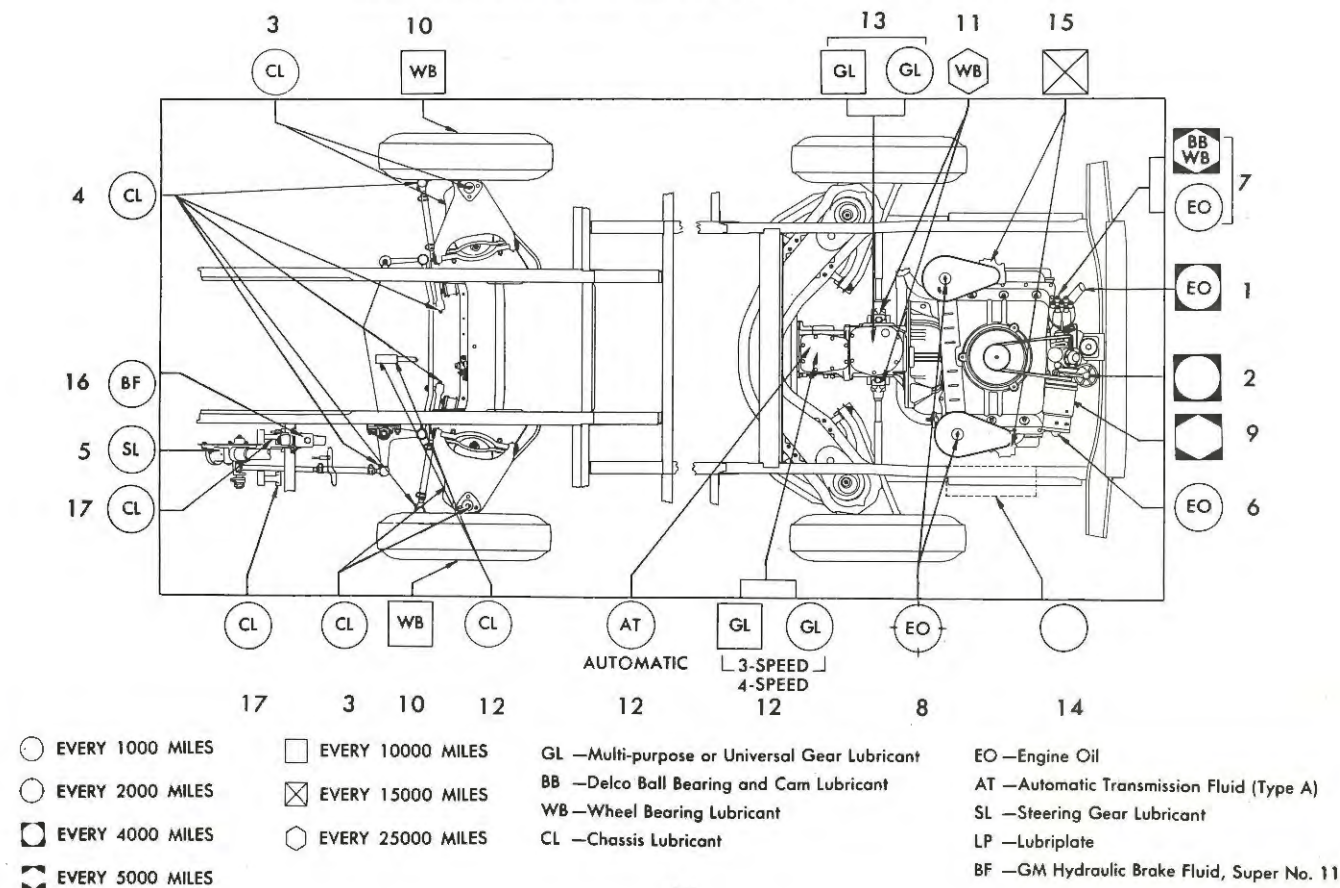

LUBRICATION AND MAINTENANCE GUIDE

The following lubrication and maintenance recommendations are intended as a guide for vehicles operated under normal driving conditions. Sustained heavy duty or high speed operation, or operation under adverse driving conditions may necessitate more frequent lubrication and maintenance.

	Every 2 Weeks	Fall	First 1000 Miles	Every 1000 Miles	Every 2000 Miles	Every 4000 Miles	Every 5000 Miles	Every 10,000 Miles	Every 15,000 Miles
Check Battery		•							
Check Air in Tires		•							
◆ Add W/Washer Solvent and Anti-Freeze to Washer Bag			•						
Change Engine Break-in Oil				•					•
Change Rear Axle and Manual Transmission Lubricant					•				
Check Engine Oil Level						•			
Lubricate Chassis						•			
Lubricate Clutch and Brake Pedals						•			
Oil Generator – Oil Battery Terminals						•			
Fill Distributor Hinge Cap Oiler						•			
Check Transmission Lubricant						•			
Check Rear Axle Lubricant						•			
Check Brake Master Cylinder Fluid Level*						•			
Check Steering Gear Box Lubricant						•			
Inspect Tires						•			
Check Fan Belt						•			
†Clean and Re-Oil Air Cleaner Elements							•		

- *Add only G. M. Hydraulic Brake Fluid Super No. 11.
 ◆ Never use any windshield solvent or anti-freeze containing Methanol.
 †Service every 1000 miles during extremely dusty operation

LUBRICATION AND MAINTENANCE GUIDE

The following lubrication and maintenance recommendations are intended as a guide for vehicles operated under normal driving conditions. Sustained heavy duty or high speed operation, or operation under adverse driving conditions may necessitate more frequent lubrication and maintenance.

	Every 2 Weeks	Fall	First 1000 Miles	Every 1000 Miles	Every 4000 Miles	Every 5000 Miles	Every 10,000 Miles	Every 15,000 Miles	Every 25,000 Miles
Regular Engine Oil Change						•			
Change Oil Filter Element**						•			
Engine Tune-Up							•		
Lubricate Distributor Cam and Breaker Pivot							•		
Lubricate Exposed Clutch Linkage							•		
Clean Engine Oil Cooler							•		
Adjust Brakes							•		
Rotate Tires							•		
Clean and Regap Spark Plugs (.035" Gap)							•		
Repack Front Wheel Bearings								•	
‡Drain and Refill Rear Axle and Manual Transmission								•	
Replace Carburetor Fuel Filters									•
Repack Universal Joints									•
COMPLETE DEALER INSPECTION							•		

- **Change Oil Filter Element after first 5000 miles and every 4000 miles thereafter.
 ‡ Or Seasonally.

SPECIFICATIONS

SERIAL AND UNIT NUMBERS

Serial Number... Stamped on plate attached to left center body pillar.
 Body Number... Stamped on a plate attached to the left rear wheel well, within the engine compartment.
 Engine Number... Stamped on the engine block behind and to left of the fuel pump.

DIMENSIONS

GREENBRIER AND CORVAN

Overall Length	179.7 in.
Overall Height	68.5 in.
Overall Width	70.0 in.
Wheelbase	95.0 in.
Turning Diameter	42.6 ft.
Load Compartment	
Height	54.0 in.
Length	106.2 in.
Width	59.4 in.
Side Loading Doors	49.0 x 53.5 in.
Rear Doors	36.0 x 44.6 in.
Curb Weight—Corvan	2805 lbs.
Greenbrier	3005 lbs.
Payload Capacity—Corvan	1795 lbs.
Greenbrier	1595 lbs.
Cubic Capacity—Corvan	191 cu. ft.
Greenbrier	175 cu. ft.

LOADSIDE AND RAMPSIDE

Overall Length	179.7 in.
Overall Height	69.0 in.
Overall Width	70.0 in.
Wheelbase	95.0 in.
Turning Diameter	42.6 ft.
Load Length	103.3 in.
Load Width	61.8 in.
Platform Height	26.5 in.

Tailgate	44.8 in. wide
Rampgate	47.5 in. wide
Curb Weight—Loadside	2705 lbs.
Rampside	2715 lbs.
Payload Capacity—Loadside	1895 lbs.
Rampside	1885 lbs.
Cubic Capacity	80 cu. ft.

CAPACITIES

Gasoline Tank	18.5 gal.
Crankcase Refill	4 qt.
Add for Filter	1 pt.
Transmission	
3-Speed	2 pt.
4-Speed	3 pt.
Powerglide	
(Refill)	4 1/2 to 8 pts. (depending on drain period)
Differential	3 pt.
Air Cleaners	Polyurethane Element
Cooling System	Air Cooled Engine

TIRE INFORMATION

Type	Tubeless Tyrex	
Size	Standard—7.00 x 14—4 ply	
	Optional—7.00 x 14—6 ply	
Inflation	COLD	HOT
7.00 x 14—4 ply (std.)	24	28
7.00 x 14—6 ply (optional)	28	32

ENGINE SPECIFICATIONS

Horsepower:	
Turbo Air (Production)	.80 @ 4400 rpm
Super Turbo Air (Optional)	.98 @ 4600 rpm
Compression Ratio	8.0:1
Displacement	145 cu. in.
Bore	3.437 in.
Stroke	2.60 in.
Firing Order	1-4-5-2-3-6

Spark Plugs	AC-46FF (Gap: .035)
Idle Speed	
3-Speed	450-500 RPM (in Neutral)
4-Speed	450-500 RPM (in Neutral)
Powerglide	475-500 RPM (in Drive)
Ignition Timing	
All Manual Transmissions	4° B.T.D.C.
Automatic Transmission	13° B.T.D.C.

AXLE RATIO

3-Speed Transmission	3.89:1
4-Speed Transmission	3.27:1
Powerglide	3.89:1

BULB SPECIFICATIONS

	Candle Power	Number
Headlamp Unit—Outer: High Beam	37 1/2 W	4002 (Sealed Beam)
Low Beam	50 W	4001 (Sealed Beam)
Inner: High Beam	37 1/2	1034
Parking Lamp and Directional Signal	4-32	1034
Tail and Stop and Turn Signal Lamps	4-32	1073
Back-up Lamp	32	1073
Instrument Lamps	3	GE 1816
Directional Signal Indicator Lamp	1	53
Temperature-Pressure Indicator Lamp	2	57
Generator-Fan Indicator Lamp	2	57
Headlamp High Beam Indicator Lamp	1	53
Ignition Lock Lamp	1	53
Glove Compartment Lamp	2	57
Dome Lamp	15	211
Courtesy Lamp	6	89

License Plate Lamp	4	67
Radio Dial Lamp	2	1891
Heater Control Panel Lamp	1	53

FUSES AND CIRCUIT BREAKERS

A circuit breaker in the light control switch protects the headlamp and parking lamp circuits, thus eliminating one fuse. When current load is too heavy, the circuit breaker rapidly opens and closes, protecting the circuit until the cause is found and eliminated.

Fuses, located in the Junction Block beneath the dash are:

1. Heater Blower
Glove Compartment Lamp 3AG/AGC-10 amp.
2. Tail and Stop Lamps,
Direction Signals 3AG/AGC-10 amp.
3. Heater (Total System)
Back-up Lamp 3AG/AGC-20 amp.
4. Radio 3AG/AGC-4 amp.
5. Instrument Panel Lamps
Radio Panel Lamp 3AG/AGC-3 amp.
Heater Control Panel Lamp

FUSE BLOCK

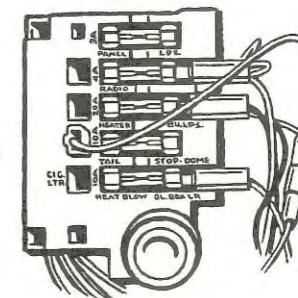

Your Authorized Chevrolet Dealer carries a complete stock of Chevrolet Service Accessories, especially developed for use in keeping your Corvair 95, or any Chevrolet, looking and feeling like new for years to come. Many of these accessories are available for "do-it-yourself" work on your Corvair 95, or, if you desire, your Chevrolet Dealer has many cleaning and polishing services to offer.

EXTERIOR CAR CARE

All cleaners, polishes and tar removers in the following list have been especially compounded for use on Chevrolet Magic Mirror Acrylic Finishes.

- *Lustur Seal
- *Porcelainize
- Triple Action Polish
- Liquid Glaze
- Tar and Road Oil Remover
- Chrome Polish
- Chrome Gard
- White Wall Tire Cleaner
- Angoro Washing Mitt
- Polishing Cloth
- Touch-up Paint in Chevrolet Colors

*Undercoating

*-Dealer Applied

SERVICE ACCESSORIES

INTERIOR CAR CARE

Use the following accessories to keep the interior of the car in new car condition.

- Kar-Kleen Cleaner
- Spot Remover
- Leather Cleaner

MISCELLANEOUS

Designed to assure proper operation of various components of your Corvair 95, the following accessories will help to rid your car of all annoying squeaks and rattles.

- No. 988299 Windshield Washer Anti-freeze and Solvent
- Door Ease Stick Lubricant
- Spray-a-squeak Silicone Lubricant
- Lock Ease Lubricant
- Ruglyde Rubber Lubricant and Cleaner
- Sealzit Glass Cleaner
- Penetrating Oil, Dripless
- Lubriplate

MINOR TROUBLE SHOOTING GUIDE

	FUEL SYSTEM AND ENGINE								ELECTRICAL SYSTEM								COOLING SYSTEM				
	Check Fuel Gauge	Flooded Carburetor	Empty Carburetor Bowl	Poor Fuel Supply to Carburetor	Idle Adjustment*	Stuck Choke Valve*	Oil Level and Pressure	Condition of Air Cleaners	Malfunctioning Ignition Switch	Automatic Transmission Selector Lever	Check Spark	Battery and Connections	Generator and Voltage Regulator Connections	Coil and Distributor Leads	Starter Connections and Solenoid	Damp Electrical Connections	Generator Condition*	Air Flow Through Engine Restricted	Fan Belt Condition and Tension Adjustment	Cooling System Thermostats*	Thorough Check and Tune-up Suggested*
On the following pages, see paragraph:	A	B	D	B-C-D	E	D	L	E	F	F	K	G	G	J	H	I	G	M	N	O	
See information on page number:	8						9-28	30		3-6		33					9				
CAR WILL NOT START:																					
Engine Will Turn Over	1	4		3							6			2			5				7
Engine Will Not Turn Over									2	1		3		4							
CAR WILL START—BUT:																					
Only After Repeated Tries										1											
Stalls in a Few Seconds			2	1	3																
Stalls When Hot					1	2		3													4
Idles Rough					1			2													3
Engine Overheats																		2	3	4	
"Oil" Indicator Light Comes On							1														
"Gen" Indicator Light Comes On											3	2				4		1			

*See Your Authorized Chevrolet Dealer

MINOR TROUBLE SHOOTING PROCEDURES

The chart on the previous page, and the information on the pages which follow, contains information designed to aid the average driver to discover, and possibly correct, conditions resulting in minor mechanical difficulties in his car. The chart, designed to point out possible solutions to several of the most common automotive malfunctions and point out a logical checking sequence, will lead step by step to the most likely causes and corrective procedures. If, after making the checks and adjustments suggested, the source of the trouble has not been found and corrected, it is strongly recommended that an Authorized Chevrolet Dealer inspect the vehicle and make whatever repairs or adjustments are necessary.

FUEL SYSTEM AND ENGINE

If the ignition switch will cause the engine to "turn over" or "crank" but the car will not start, check Steps A through D below.

NOTE: If continual "flooding" of the carburetor is evidenced by a carburetor wet with fuel or black exhaust smoke, perform the operation suggested in paragraph D only.

(A) The first and most obvious, and one of the most frequently overlooked, items to check when you have difficulty in starting your car is the amount of fuel in the tank. Make it a habit to check the FUEL GAUGE regularly and most especially at a time when the engine will "turn over" but will not start.



Checking Fuel Flow

(B) If the fuel tank is not empty,

you may check further to see whether the fuel is reaching the carburetor. Disconnect the fuel lines at the carburetors. Place a jar or cup under each open line and briefly "crank" the engine by means of the starter. If fuel spurts from the fittings, you may assume that the FUEL LINES are clear and the FUEL PUMP is operating properly. If no fuel leaves the lines, either the fuel lines or fuel pump are at fault. See your Authorized Chevrolet Dealer.

(C) Before reconnecting the fuel lines to the carburetors, remove the FUEL FILTER from one carburetor inlet and check its condition. If it appears to be clean, replace it and reconnect the fuel lines. If the filter appears to be plugged, clean it as well as possible by scraping out the foreign material and cleaning in a solvent. Then reinstall the filter and repeat the procedure with the second carburetor. Replace the filters with new ones as soon as possible.

(D) If the fuel seems to be reaching the carburetors properly, the problem may be: an EMPTY CARBURETOR BOWL caused by a "stuck shut" carburetor or a FLOODED CARBURETOR caused by a "stuck open" condition and evidenced by gasoline flowing down the outside of the carburetor; or a stuck CHOKE valve. Remove the air cleaners from the carburetors. Check that the choke valves move freely and are not stuck. Tap the side of the carburetors sharply several times with a light tool such as a screwdriver handle or pliers. Replace the air cleaners and attempt to start the engine in the normal manner.

(E) If the car will start but stalls when hot or has a rough idle, you can suspect a faulty IDLE ADJUSTMENT, or extremely dirty

and blocked AIR CLEANER ELEMENTS. Clean and reoil (see page 30) your air cleaner elements if necessary. Idle adjustment should be performed by your Chevrolet Dealer.

If the above Fuel System checks and the checks suggested under the Electrical System following do not correct the malfunction, it is recommended that you turn to your Authorized Chevrolet Dealer for further checks, adjustments or repairs.

ELECTRICAL SYSTEM

If, when the ignition key is turned to "Start", the engine will not turn over, you have good reason to suspect electrical trouble.

(F) When there is no response at all to attempts to start the car, check the obvious—your AUTOMATIC TRANSMISSION SELECTOR LEVER must be in Neutral position before the engine can be started. Turning the IGNITION SWITCH rapidly back and forth several times will sometimes correct a poor internal switch contact.

(G) The BATTERY may be discharged. If so, lights will be dim and the horn will have a poor tone if it will blow at all.

Usually a garage recharge will be necessary to return the battery to operation. Occasionally, however, a push start and a long drive will recharge the battery.

NOTE: If the battery is determined to be dead, and for no apparent reason, have your Authorized Chevrolet Dealer check the battery, the GENERATOR and the VOLTAGE REGULATOR. GENERATOR trouble should already have been indicated by the generator indicator light on the instrument panel.

POOR BATTERY CONNECTIONS may be suspected if the car has operated properly a short time before and now not even the horn will operate. Check both ends of both battery cables. If the connections are corroded, a car may sometimes be restored to operation by removing all cable ends, scraping all contacting surfaces clean with a pen knife, and reassembling. If the cables are broken, they must be replaced. The power supply should now be restored unless the battery is dead.

(H) If, however, the lights and horn work properly but the starter will still not turn over, check the STARTER connections. A "click" from the starter solenoid indicates that the wiring to the starter is properly installed. If the wiring seems to be clean and tightly installed, the trouble is probably in the starter itself and should be referred to your Authorized Chevrolet Dealer.

When the engine will "turn over" but will not start, the following items may be checked along with Fuel System Checks listed previously.

(I) With a clean dry cloth wipe the ceramic portions of the spark plugs dry. In particularly damp or rainy weather dampness may be the cause of not starting, especially when the engine is cold.

(J) Check the cables at the top of the distributor and coil as well as each spark plug cable for tightness.

(K) If the car will still not start, check for spark at the spark plugs in the following manner:

Pull one of the spark plug wires off its spark plug. Insert a short piece of bare wire (such as a bobby pin) between the rubber



Distributor and Coil Leads

cup at the end of the spark plug wire and the tubular metal connector inside of it. If the spark plug wire is wet or oily, wipe it dry. Wrap a dry handkerchief or facial tissue, folded several thicknesses, around the wire at least three inches back from the end and grasp wire at this point. Hold the bare wire about 1/4 inch from the bare tip of the spark plug from which you removed the wire. When the engine is "turned over" a spark should jump across the 1/4 inch space, indicating ample current supply. If no spark jumps, the difficulty is probably caused by a defective ignition part and should be corrected by your Authorized Chevrolet Dealer.

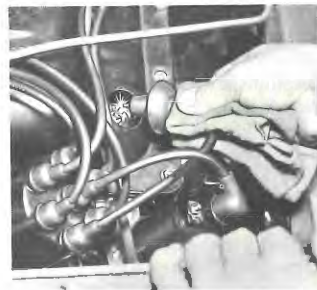

Checking for Spark

COOLING SYSTEM

When the car will run but evidences serious overheating on the temperature gauge in the instrument panel, there are several items which may be checked.

(L) Engine overheating will occur when the OIL LEVEL falls dangerously low. Check the oil level as a matter of course.

CAUTION: Never drive the car when the "TEMP-PRESS" indicator in the instrument panel is lighted.

(M) Check the air intake louvers. Clean them if they are plugged with leaves or other foreign material.

(N) Condition of the FAN BELT is very important, not only for engine cooling but also for proper generator operation. Check the condition of the belt. Replace it if it is worn or frayed. Loosen the idler bracket bolts and move the bracket toward the engine to remove and replace the belt. Tighten the belt, whether new or old, by loosening the idler bracket nuts, prying with a bar on the bracket until the belt is tensioned properly, then retighten the bracket bolts. Proper belt tension is such that, when pulled hard at a point midway between the generator and fan pulleys, the belt will deflect about 3/8 inch.



Checking Fan Belt Tension

(O) Another cause of engine overheating may be an inoperative COOLING SYSTEM THERMOSTAT. If the thermostat should fail in the closed position, it will not permit air to circulate through the engine. See your Authorized Chevrolet Dealer.

INDEX

	Page
Air Cleaner	30
Air Vents	17
Ash Tray	17
Axle Ratios	39
Battery	33
Brake Master Cylinder	34
Brake—Parking	12
Brakes	12
Breaking-in Period	2
Bright Metal Parts	22
Type and Location	23
Bulb Specifications	39
Chassis Lubrication	28
Choke	3
Cigarette Lighter	17
Circuit Breaker	39
Cleaning Hints	22
Clutch Pedal	12 and 34
Clutch Linkage	34
Cooling System	25
Crankcase Lubrication	24 and 28
Dimensions	38
Dimmer Switch	11
Distributor	30
Doors and Locks	17-18
Driving for Economy	2
Engine Oil Cooler	31
Engine Compartment Access	28
Engine Lubrication	24-25
Engine Specifications	38
Exterior Appearance	22
Washing	22
Polishing	22
Bright Metal Parts	22
White Sidewall Tires	22
Front Suspension	29
Front Wheel Bearings	31
Fuel Filter	33
Fuel Gauge	8
Fuses	39
Gas Cap	21
Generator	30
Gen-Fon Indicator	9
Heater	
Gasoline	14
Direct Air	15
Ignition Switch	3

	Page		Page
Interior Appearance	23	Serial and Unit Numbers	38
Jacking the Car	26	Spare Tire	27
Keys and Locks	18	Specifications	38
Light Control Knob	10	Speedometer	8
Locks	18	Starting the Engine	3
Lubrication Diagram	35	Steering Linkage	29
Lubrication & Maintenance Guide	36-37	Steering Gear	29
Maintenance and Lubrication	24	Switching Tires	27
Octane Requirements	24	Tailgate	20
Oil Filter	28	Temp-Press-Indicator	9
Parking Brake		Tire Care	26
Operation	12	Tire Information	38
Polishing Your Corvair	22	Towing—Powerglide	7
Pushing to Start		Transmission	
Manual	5	Manual	
Powerglide	7	Operation	4
Radios	16	Service	22
Rampgate	20	Powerglide	
Rear Axle	33	Operation	6
Rocking Car—Powerglide	7	Service	32
Seats		Trouble Shooting Guide	41
Front Seat Adjustment	20	Turn Signal	11
Second Seat	21	Universal Joints	31
Service Accessories	40	Warm-up	4
Service Brakes	12	Washing Your Corvair	22
		White Sidewall Tires	22
		Windshield Wipers and Washers	13

OWNER SERVICE POLICY

Upon delivery of your new Chevrolet Corvair 95, you received an Owner Service Policy which you should read carefully. Keep this policy with you during the warranty period as it serves to introduce you to any Chevrolet dealer.

